

Frequency dividers in radar target stimulator applications

M. Vorderderfler, M. E. Gadringer, H. Schreiber, A. Gruber, W. Bösch, S. Metzner, H. Pflügl, M. Paulweber

More and more driver assistance systems are integrated into modern vehicles. This development results in a continuous rise in the complexity of these vehicles, as the functions have to comply to the corresponding safety standards. Testing and validating these functions on an automotive test bench instead of driving tests at closed proving grounds requires comprehensive stimulation of the involved sensors. In this article we are focusing on an approach for stimulating short-range radar sensors of a vehicle located on such a test bench. Coping with the requirements imposed by these types of sensors we investigate the usage of frequency multipliers and dividers in the frequency translation section of the radar stimulator. For this purpose, we provide an overview on different concepts for these multipliers and dividers. After reviewing the advantages and disadvantages of these devices, we provide measurement results of a stimulator setup applying this type of frequency translation.

Keywords: radar systems; test equipment; radar applications; radar equipment; radar signal processing; radio frequency circuit design

Frequenzteiler und ihre Anwendung in Radar-Target-Stimulatoren.

Fahrassistenzsysteme spielen eine immer größere Rolle in modernen Fahrzeugen. Die Integration dieser Systeme und die damit verbundene Einhaltung der nötigen Vorschriften und Sicherheitsstandards erhöhen die Komplexität der Fahrzeuge enorm. Um die Funktionsprüfung von Fahrassistenzsystemen auf dem Prüfstand durchführen zu können, ist eine umfassende Stimulation der Sensoren des Systems notwendig.

Dieser Beitrag behandelt einen Zugang zur Stimulation automotiver Radarsensoren für den Nahbereich auf einem Prüfstand. Dabei wurde die Verwendung von Frequenzmultiplikatoren und Dividierern im Frequenzumsetzungspfad des Radar-Stimulators untersucht. Der Artikel gibt einen Überblick über verschiedene Konzepte zur Realisierung dieser Funktionsblöcke. In der Folge werden die Vor- und Nachteile der in Verbindung mit einem Radar-Target-Stimulator verwendeten Konzepte aufgezeigt und Messergebnisse präsentiert.

Schlüsselwörter: Radarsysteme; Testequipment; Radaranwendungen; Radarequipment; Radarsignalverarbeitung; HF-Schaltungsdesign

Received March 26, 2018, accepted May 24, 2018
© The Author(s) 2018



1. Introduction

Driver assistance and active safety functions evolve to an important factor in the perception of vehicles. Advanced Driver Assistance Systems (ADAS) like adaptive cruise control (ACC), collision mitigation and avoidance systems (CMS) or lane change assist (LCA) release the driver and support his awareness during monotonous driving tasks [1]. The integration of these solutions requires comprehensive sensing of the environment. The positions of moving and stationary objects surrounding the vehicle have to be detected and classified accurately. This functionality is mandatory for reacting adequately in all possible traffic scenarios [2].

From the variety of employed sensors the radar is already used successfully for many driver assistance functions. It has the unique ability to monitor the distance and velocity of detected objects. For this task, a significant effort was dedicated into the clustering of the point clouds of input signals related to a single physical object to its virtual correspondent. Extracting features from the scattered signals like radar cross-section (RCS) and Micro-Doppler, object classification can be achieved. This approach allows classifying objects in, for example, pedestrians, cars, trucks, etc.. Another important aspect of radar sensors is their ability to operate much better under harsh conditions such as rain, fog or snow as other types of sensors [2–7]. The importance of ADAS functions is also expressed by the negotiation achieved by the U.S. National Highway Traffic Safety Administration

(NHTSA) with 20 carmakers. They agreed on voluntarily equip all production vehicles with CMS by 2020, a safety feature which is often enabled by radar sensors [6].

These benefits are driving carmakers to integrate more radar sensors into their products. As an example, Fig. 1 provides an overview of possible radar sensor locations at a car. Additionally, the relationship between the radar sensor types, i.e. short-range (SRR), mid-range (MRR) and long-range radar (LRR), and the corresponding ADAS functions is highlighted [3, 8]. Automotive Radar Sensors typically operate in the frequency range 76–81 GHz applying the Frequency Modulated Continuous Wave (FMCW) modulation scheme [6, 7, 9, 10]. LRRs operating under these prerequisites are capable to

Vorderderfler, Michael, Institute of Microwave and Photonic Engineering, Graz University of Technology, Inffeldgasse 12, 8010 Graz, Austria (E-mail: michael.vorderderfler@tugraz.at); **Gadringer, Michael E.**, Institute of Microwave and Photonic Engineering, Graz University of Technology, Inffeldgasse 12, 8010 Graz, Austria; **Schreiber, Helmut**, Institute of Microwave and Photonic Engineering, Graz University of Technology, Inffeldgasse 12, 8010 Graz, Austria; **Gruber, Andreas**, Institute of Microwave and Photonic Engineering, Graz University of Technology, Inffeldgasse 12, 8010 Graz, Austria; **Bösch, Wolfgang**, Institute of Microwave and Photonic Engineering, Graz University of Technology, Inffeldgasse 12, 8010 Graz, Austria; **Metzner, Steffen**, AVL List GmbH., Hans-List-Platz 1, 8020 Graz, Austria; **Pflügl, Horst**, AVL List GmbH., Hans-List-Platz 1, 8020 Graz, Austria; **Paulweber, Michael**, AVL List GmbH., Hans-List-Platz 1, 8020 Graz, Austria

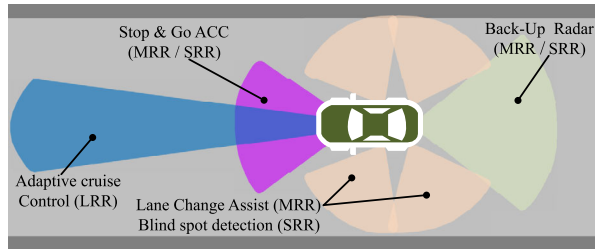

Fig. 1. Location of radar sensors in a car and the corresponding ADAS functions

cover distances up to 250 m with spatial resolution typically around 0.5 m. To accomplish these specifications a bandwidth of the FMCW transmit signal of up to 1 GHz is utilised. The SRRs typically provide a detection range between 0.2 and 30 m, a range (object) resolution of 15 cm and a range accuracy of 7.5 cm while applying a transmit signal bandwidth of up to 4 GHz [8, 9].

The growing number of ADAS functions integrated into a vehicle, as highlighted before, increases the complexity and cost of its development [11]. Furthermore, it is a well established safety principle that computer-based systems should be considered unsafe unless convincingly argued otherwise (i.e., safety must be shown, not assumed). Therefore, ADAS safety features cannot be considered safe unless and until they meet widely accepted (software) safety standards [12]. These requirements demand for new methods to integrate simulation and test on each level of the validation chain. Especially for the development of ADAS safety functionality, the interaction between the car and the environment are very important and must be considered in detail. One way of validating these functionalities is closed proving ground and on-road testing under real-world conditions [13]. The restraints imposed by weather, lighting and other practical limitations makes the Vehicle-in-the-Loop (ViL) test approach an attractive alternative [13–16]. This test approach requires stimulating all underlying sensor systems appropriately. Focusing on the radar sensor and considering scenarios for the ViL test including traffic moving in close distance to the location of the sensor impose demanding requirements on the equipment stimulating the sensors [14, 16]. For an Over-the-Air (OTA) test a Radar Target Stimulator (RTS) must capture the signals transmitted by the radar sensor and process it corresponding to the scattering caused by the physical object which should be detected and, thereafter, retransmit it to the sensor. The time duration for such processing steps is limited by the speed of light required to go forth and back to the object which should be stimulated. Hence, the closer the object to be stimulated and the wider the bandwidth of the transmit signal of the radar sensor the more difficult the stimulation of the object comes.

In [14–16] we introduced radar target stimulation with application to ViL testing of ADAS functionality. In this article we are focusing on the stimulation of radar targets for SRRs. For this purpose, wide-band signals must be processed with very low latency for a proper stimulation. Still complex traffic scenarios should be covered by the selected approach. For this goal, we summarise the implementation of a RTS in Sect. 2. In a typical RTS system one or more mixing stages are used to translate the Radio Frequency (RF) input signal into the Intermediate Frequency (IF) range and back again. In Sect. 3 we suggest using frequency dividers and multipliers for these frequency translation tasks. The advantages and disadvantages of this approach are discussed and different implementation approaches of

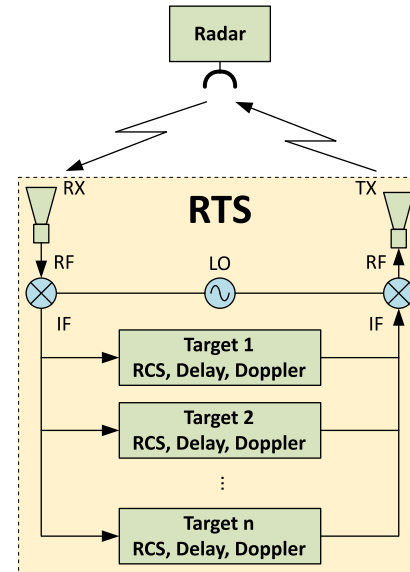

Fig. 2. Basic principle of a RTS applying IF signal processing

frequency dividers are summarised. The performance of a RTS applying frequency dividers and multipliers is highlighted in Sect. 4 before we provide a summary of the concept in Sect. 5.

2. System concept

The operational principle of a radar sensor is based on analysing the electromagnetic waves scattered at different objects. By comparing the transmitted and the received waves, it evaluates the distance between the radar and the object (also called “target”) and the RCS which is related to the reflectivity of the object. Additionally, the angle of the received wave (i.e.: its direction) as well as the relative velocity can be detected [17, 18].

The aim of radar target stimulation is to capture the transmit signal of the radar, process it, and retransmit it to the sensor. By this procedure the RTS must ensure, that the radar sensor’s signal processing can retrieve the stated properties from the evaluation of its received signal [14–16]. Furthermore, this task must be accomplished for all objects which are concurrently present within the detection range of the sensor. To fulfil the stated requirements the RTS must introduce the following properties to the signal captured from the radar sensor for all targets independently [15, 16]:

- a time delay corresponding to twice the distance to the target,
- a Doppler frequency shift according to the relative velocity between the target and the sensor,
- an attenuation based on the target’s RCS and distance.
- the desired receive angle of the reflected wave

For RTS scenarios covering more than one object, it is usually simpler and more cost effective not to perform these manipulations at the RF range of the sensor’s transmit signal. Instead, the signal captured by the RTS is shifted to an IF at which these changes can be efficiently applied [14, 19–22]. This approach is summarised by the simplified block diagram presented in Fig. 2. Here, the sensor is stimulated OTA. By applying a single (fixed) antenna for the retransmission only one receive angle is supported. In this case the RTS captures the radar sensor’s transmit signal by the RX antenna and downconverts it to the IF range by mixing with the Local Oscillator (LO). Here, the RCS, time-delay and Doppler shift are introduced for each target separately. Thereafter, the responses for all targets are

combined before they are upconverted to the RF and retransmitted to the sensor. Any image reject filtering and signal treatment associated with up- and downconversion are excluded to simplify the block diagram.

The concept shown in Fig. 2 can be applied to any type of automotive radar (SRRs, MRRs, and LRRs). The typical detection range of SRRs (0.2 to 30 m) corresponds to a time delay of approx. 2 to 200 ns [17, 23]. From the RTS point of view, this time duration must include the time for the wave propagation from and to the sensor and also the frequency translations and IF signal processing. Due to this reason, the minimum distance for an OTA radar target stimulation is around 2–5 m in case of IF signal processing RTS implementations [14]. Moreover, even ultra-low latency digital signal processing systems capable of handling the full RF signal bandwidth are not able to meet these timing constraints for a real-time processing of the Doppler shift, RCS and time delay [15, 16]. Thus, the stimulation of SRRs demand for an analogue implementation of the IF signal processing in order to provide reasonably low stimulate-able target distances.

Despite of using an analogue implementation the wide RF signal bandwidths of SRR of up to 4 GHz make its realisation a demanding task as well. Depending on the selected IF frequency, large relative bandwidths can complicate the Doppler shift processing. If more than one target is required at the RTS, this processing step is typically implemented using vector modulators [24–26]. On the one hand, moving to a higher IF frequency range alleviate the requirements imposed on the vector modulators. On the other hand, the implementation of variable analogue delay lines gets more lossy and costly.

In summary, the stimulation of multiple targets at a SRR is a demanding task. The complexity of the analogue implementation for the different processing steps depend on the selected IF frequency range. Lowering the IF simplifies the variable analogue delay line and impedes the vector modulator implementation. Hence, either lowering or increasing the IF range shifts complexity between the different processing steps. To reduce the complexity of the whole IF processing altogether, conceptually different solutions must be taken under consideration.

3. Frequency divider and multiplier based RTS system

The RTS system presented in Fig. 2 uses a mixer based frequency translation. In the ideal case, this approach performs a perfect shift of the input signal to a different frequency range. The bandwidth of the associated signals stays the same during this process. The phase noise produced by the LO generator is often the most important degradation mechanism associated with this frequency translation process [27]. The usage of a LO showing phase noise results in a slight spreading of the bandwidth of the input signal after the frequency translation [28]. For the RTS the impact of the phase noise is in a large part mitigated by applying the same LO for the down- and upconversion [14, 23].

A fundamentally different approach of frequency translation is highlighted in Fig. 3. Here, a frequency divider and multiplier perform the down- and upconversion. In a first step we will focus on the downconversion performed by the frequency divider. As the name suggests, a frequency divider divides a signal in the frequency domain. From a system engineering point of view the divider's input signal is deconvoluted resulting in a downward shift of the input signals' frequency as well as a compression of the bandwidth. Clearly, before sending the processed IF signal back to the radar, a signal reconstruction is needed. This is where the frequency multiplier comes into play. A frequency multiplier is a non-linear component which

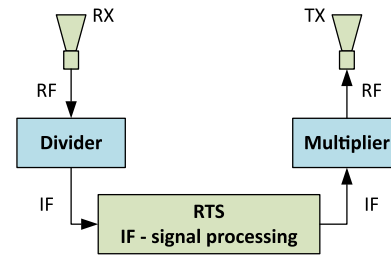

Fig. 3. Principle of frequency conversion with a divider and a multiplier

performs the multiplication of its input signal with itself. So, the signal is shifted upwards in the frequency domain and the bandwidth is enhanced again. Hence, if the downconversion in the receive (RX) path is accomplished by a frequency divider, the upconversion in the transmit (TX) path has to be performed by a multiplier (Fig. 3). The frequency divider and the frequency multiplier must show the same divider/multiplier factor.

Two implementations of frequency dividers are commonly used: digital and analogue dividers [29]. Digital frequency dividers are realised with binary counters or shifting registers. For simple power-of-2 integer division, these kind of dividers are very easy to implement. An arrangement of clocked flip-flops can provide an accurate division which is frequency and phase coherent to the source. The operation frequency of digital dividers is restricted by the technology in which the circuitry is manufactured. CMOS based digital frequency dividers applying Current Mode Logic (CML) showed to be able to operate at frequencies as high as 80 GHz [30]. Implementation of digital frequency dividers in SiGe or InP Technology are demonstrated to handle input frequencies above 300 GHz [31].

Using properly designed input stages of the digital divider a certain input power range can be supported, in which the desired operation can be guaranteed. As the output of this divider type is composed of digital gates, only constant amplitude signals are provided. The loss of the information about the input signal magnitude is, therefore, the main drawback of digital frequency dividers. Apart from that, digital dividers would be a good choice for RTS applications. As long as the signal transmitted by the radar sensor shows a constant amplitude the RTS concept presented in Fig. 3 using digital frequency dividers can be applied. For the important class of FMCW radars this condition is commonly fulfilled.

To overcome these problems, analogue frequency dividers provide an alternative approach. Below, two types of this class of dividers will be discussed. Firstly, the injection locked frequency dividers are one class of analogue frequency dividers, which are often used in phased locked loops (PLL). They work like injection locked oscillators. There, a continuous oscillation is provided by a LC tank which can be slightly changed by feeding a input signal showing a frequency in range of the oscillation frequency. The oscillator will lock onto the injected signal [32]. This behaviour also works when the injected signals' frequency lies at harmonics or subharmonics of the oscillator. The disadvantage of this divider is the small locking frequency range and, therefore, the small bandwidth of the divider. For radar target stimulation also the continuous oscillation, independent from an applied input signal, is unwanted. Another class of analogue dividers are the so called regenerative frequency divider (RFD) also called Miller divider. This regenerative divider is a possible solution to the problems and disadvantages of the above mentioned dividers [33]. The schematic principle of the regenerative frequency

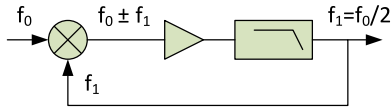

Fig. 4. Block diagram of a regenerative frequency divider (divides by 2)

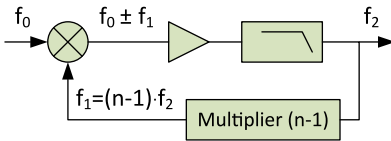

Fig. 5. Block diagram of a divide by n regenerative frequency divider

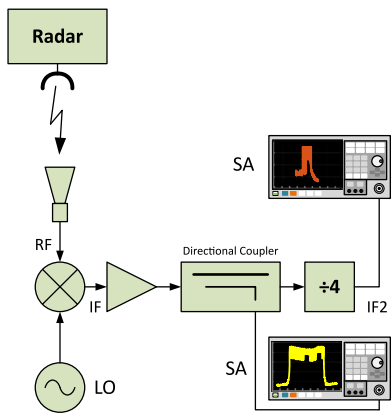

Fig. 6. Setup to measure the frequency division and bandwidth compression of the radar signal

divider is shown in Fig. 4 [33]. The basic circuit of this divider is a combination of a mixer (multiplier), an amplifier and a filter arranged in a closed loop. The input signal with a specific frequency f_0 is multiplied with a second signal at a frequency f_1 . The output of the mixer consists of a lower and a upper sideband of the mixed input frequencies described by Eq. (1):

$$f_{mix} = f_0 \pm f_1 \tag{1}$$

After removing the undesired frequency band with a following low pass filter, it's output signal is fed back to the second port of the

mixer (f_1), resulting in

$$f_1 = f_0 - f_1 \rightarrow f_1 = \frac{f_0}{2} \tag{2}$$

Equation (2) reveals the behaviour of the RFD in its basic configuration. The circuits' only possible output frequency is restricted to the half of the input signals frequency. As mentioned before, not only the frequency is divided by 2 but also the bandwidth is compressed by the same factor.

To achieve a higher order of division, the original circuit has to be modified as shown in Fig. 5 [33]. A multiplier with the factor $n - 1$ in the feedback loop changes the output frequency of the divider to,

$$f_2 = f_0 - (n - 1) \cdot f_2 \tag{3}$$

which results in the output frequency of:

$$f_2 = \frac{f_0}{n} \tag{4}$$

These steady state conditions of such RFDs are rather simple but, in exchange, it is more complicated to get this circuit started [33–36]. The most important requirement in this context is meeting the so called Barkhausen criterion; the loop gain of the circuit has to be greater than unity as well as the phase shift in the loop must be a integer multiple of π [33].

If all conditions are met the RFD will lock onto a fraction of the input frequency and follows its changes. Hence, if no input signal is present the output signal will vanish, which is very useful for RTS applications. Another advantage is the level dependency of the output on the input signal [33]. Additionally, the already mentioned bandwidth compression and phase noise reduction compared to mixer / LO based downconversion make this divider a very good choice for the intended usage.

4. System results

To verify the mentioned principle of frequency division and bandwidth compression, measurements were performed. Therefore, the signal of an automotive radar was captured and provided as the input of a divide-by-four frequency divider. In order to measure the input and output signal of the divider the measurement setup presented in Fig. 6 was used. A picture of this setup identifying the corresponding measurement equipment is shown in Fig. 7. For receiving the signal of the radar, the radar sensor was positioned approximately 40 cm in front of a horn antenna. The centre frequency of this sensor was located at 76.25 GHz. As the available divider is characterised by a input frequency range of about 8 GHz, mixer based

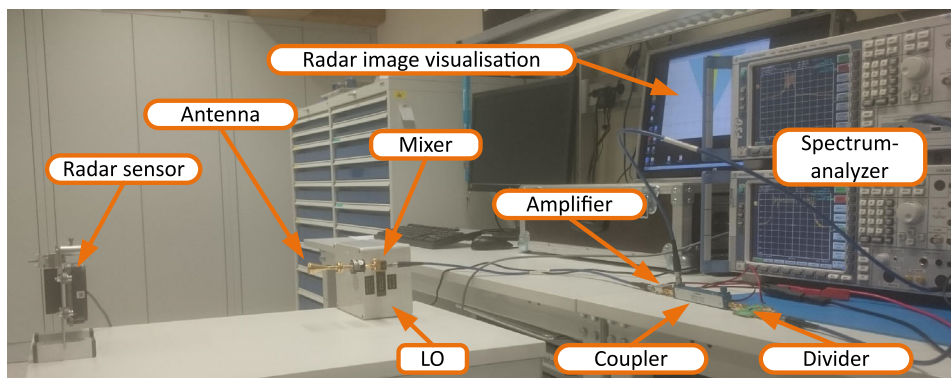

Fig. 7. Setup to measure the frequency division and bandwidth compression of the radar signal

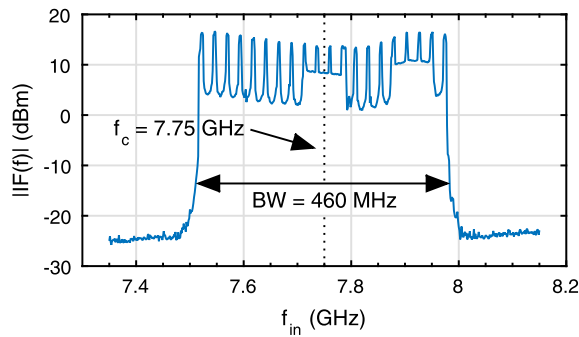

Fig. 8. Measured radar signal at the input of the divider

downconversion stage was required. Therefore, the radar transmit signal was frequency translated to 7.75 GHz using a LO generator at 68.5 GHz. Next, the IF output signal of the mixer is amplified to ensure the needed level at the input port of the divider for proper function. To measure the divider's input signal a directional coupler connected to a spectrum analyser (SA) was used. With another SA the output signal of the divider following the directional coupler was observed.

The outcome of these measurements shows the functional principle of the divider by the spectra of the corresponding signals. Figure 8 depicts the input signal of the divider after the mixer-based downconversion and the additional amplification. The signal centred at 7.75 GHz shows a signal bandwidth of approximately 450 MHz. This illustrates the full bandwidth of the radar signal transmitted by the used automotive sensor. In comparison, Fig. 9 highlights the signal at the output port of the divide-by-four frequency divider. According to the behaviour of frequency dividers, mentioned in Sect. 3, the centre frequency of the signal is now at about 1.94 GHz. Furthermore, the bandwidth is compressed to about 112 MHz – a quarter of the original bandwidth.

4.1 Frequency divider & multiplier based RTS

After visualising the behaviour of the divider in a stand-alone configuration, the applicability of frequency dividers and multipliers for RTS systems shall be highlighted. Figure 10 presents the block diagram of the corresponding RTS setup. Additionally, the picture in Fig. 11 shows the used equipment for this demonstration. As in the former setup, the signal of an automotive radar sensor was downconverted by a mixer and the subsequent frequency divider. The output of the frequency divider was then provided to an analogue radar target stimulator [14]. In this unit all IF signal processing steps necessary for radar target stimulation are accomplished (i.e.: introduction of time-delay, Doppler shift, and RCS).

Here, an important difference to the RTS applying mixer based frequency translation techniques must be considered. The delaying of the IF input signal and the scaling according to the desired RCS are invariant to the signal compression caused by the frequency divider. On the contrary, the introduction of Doppler frequency shift must consider the signal expansion taking place in the following frequency multiplier based upconversion. Therefore, the Doppler shift at the frequency divider & multiplier based RTS is

$$f_{D,divider} = f_D/n \quad (5)$$

where f_D is the frequency of the Doppler shift and n is the factor of the preceding frequency divider. It is important to note, that additionally to using $f_{D,divider}$ instead of f_D no other changes apply to the IF processing. Hence, the same IF signal processing part of the RTS

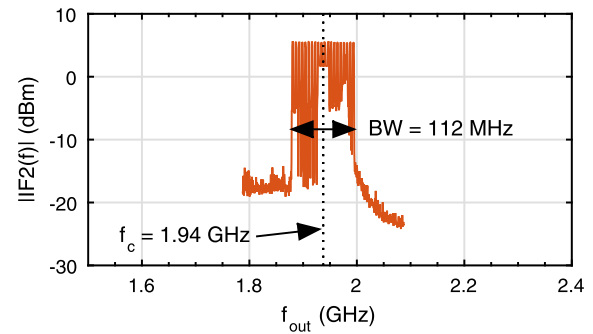

Fig. 9. Measured radar signal at the output of the divider

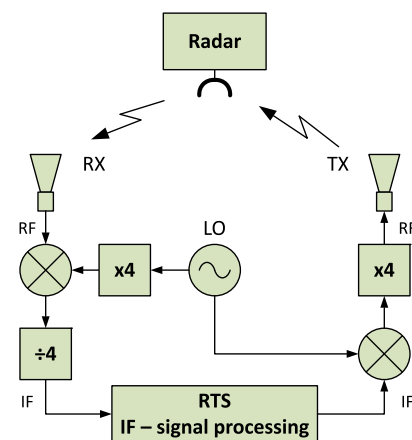

Fig. 10. Blockdiagram to perform the full down- and upconversion with a divider and a multiplier

can be used independent of the considered frequency translation approach.

The processed IF signal was then connected to the upconversion branch. This part of the RTS is not arranged in the same way as the downconversion section. Instead, in a first step a mixer based translation was performed to a second IF frequency range at around 19 GHz. This signal was then fed into a combined 4x frequency multiplier and TX antenna unit which was arranged in an array assembly. As indicated in Sect. 3, the usage of a divider in the downconversion branch demand a multiplier in the upconversion part showing the same conversion factor. A symmetrical setup of the RX and TX paths is not required. Furthermore, the radar sensor was connected to a visualisation console, where the generated radar target was visible. With this setup, we successfully demonstrated the frequency translation by frequency dividers and multipliers in radar target stimulation applications.

Depending on the length of the connecting cables (compare Fig. 11) the minimum distance of stimulateable targets is around 2.5 m of the presented setup. The maximum distance is limited by the complexity introduced to the IF section of the analogue RTS.

5. Conclusion

ADAS and safety functions provide important features for modern cars. Their test and validation on a ViL testbed requires comprehensive stimulation solutions of the underlying sensor systems. The automotive radar sensors are a major component of these systems. Different types of radars (SRR to LRR) are used in a vehicle to monitor the surrounding environment. From these radars the SRR needs

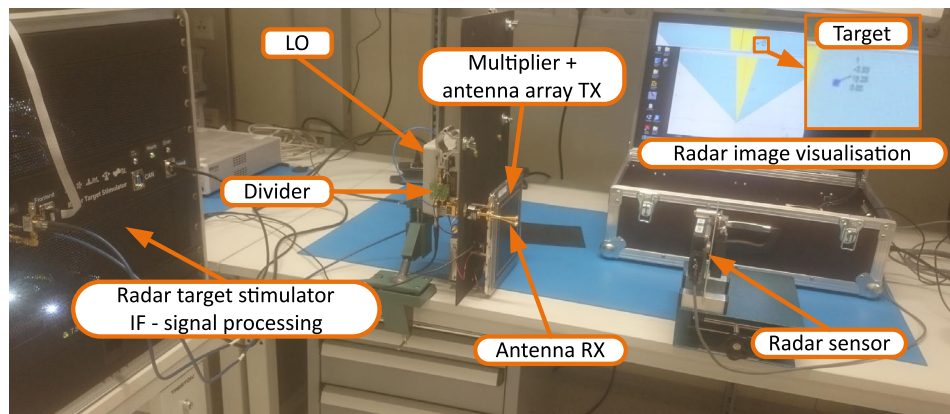

Fig. 11. Setup to perform the full down- and upconversion with a divider and a multiplier

special attention. Most importantly the SRR OTA stimulation requires the support of complex traffic scenarios even at short distances without a-priori knowledge of the sensor itself.

In this article we introduce a RTS concept applying an alternative frequency translation approach to meet these specifications. For this purpose we discussed the mixer based RTS systems in Sect. 2. In this context we highlighted, that no clear optimum regarding the complexity of the corresponding IF processing can be found. To overcome this restriction we investigated different implementations of frequency dividers in Sect. 3. The main advantage of frequency dividers in RTS systems is their inherent signal compression capability. Additionally, they can downconvert an input signal without the need for a LO. Based on the considered implementation of the frequency dividers, different drawbacks were discussed. For the digital frequency divider the independence of the output signal on the amplitude of the input signal should be noted. Alternatively, the injection locked frequency divider will provide an output signal, even if no excitation is present. The regenerative frequency divider can overcome the stated limitations. Here, care must be taken to meet the requirements for starting the divider operation.

To highlight the operational principle of frequency dividers measurement results on the response of a frequency divider driven by a radar input signal were presented in Sect. 4. Thereafter, this approach was extended for a full RTS operation. We can prove that stimulating a radar sensor is possible using the frequency divider and multiplier concept. A minimum stimulateable distance for targets indicated by the visualisation of the radar sensor of around 2.5 m were accomplished in this context. In a next step the versatility of the presented setup will be improved in order to cope with the requirements imposed by a ViL testbed.

Acknowledgements

Open access funding provided by Graz University of Technology. This work has been partially conducted within the ENABLE-S3 project which received funding from the ECSEL Joint Undertaking under grant agreement no 692455. This joint undertaking is supported by the European Union's Horizon 2020 Research and Innovation Programme and Austria, Denmark, Germany, Finland, Czech Republic, Italy, Spain, Portugal, Poland, Ireland, Belgium, France, Netherlands, United Kingdom, Slovakia, and Norway.

Additionally, this work was also funded by the Austrian Research Promotion Agency (FFG) under the research project GAZELE (No.: 848457).

Open Access This article is distributed under the terms of the Creative Commons Attribution 4.0 International License (<http://creativecommons.org/licenses/by/4.0/>), which permits unrestricted use, distribution, and reproduction in any medium, provided you give appropriate credit to the original author(s) and the source, provide a link to the Creative Commons license, and indicate if changes were made.

References

1. Watzenig, D., Horn, M. (Eds.) (2017): Automated driving. Berlin: Springer.
2. Meinel, F., Stolz, M., Kunert, M., Blume, H. (2017): An experimental high performance radar system for highly automated driving. In IEEE MTT-S international conference on microwaves for intelligent mobility, ICMIM (pp. 71–74).
3. Maurer, L., Haider, G., Knapp, H. (2011): 77 GHz SiGe based bipolar transceivers for automotive radar applications—an industrial perspective. In IEEE 9th international new circuits and systems conference (pp. 257–260).
4. Grimm, C., Breddermann, T., Farhoud, R., Fei, T., Warsitz, E., Haeb-Umbach, R. (2017): Hypothesis test for the detection of moving targets in automotive radar. In IEEE international conference on microwaves, antennas, communications and electronic systems. New York: IEEE.
5. Jamal, R., Heinze, R. (Eds.) (2017): Virtuelle Instrumente in der Praxis 2017. Berlin: VDE Verlag.
6. Spexarth, M. (2018): The future of automotive radar testing with modular solutions. *Microwave J.*, 61(3), 22–26.
7. Suh, J. (2018): The future of automotive radar testing with integrated simulation software. *Microwave J.*, 61(3), 34–38.
8. Wenger, J. (2005): Automotive radar – status and perspectives. In IEEE compound semiconductor integrated circuit symposium. New York: IEEE.
9. Meinel, H., Dickmann, J. (2013): Automotive radar: From its origins to future directions. *Microwave J.*, 56(9), 24–40.
10. Karnfelt, C., Peden, A., Bazzi, A., Shhade, G. E. H., Abbas, M., Chonavel, T. (2009): 77 GHz ACC radar simulation platform. In 9th international conference on intelligent transport systems telecommunications. New York: IEEE.
11. Hegde, R., Mishra, G., Gurumurthy, K. S. (2011): An insight into the hardware and software complexity of ecus in vehicles. In D. C. Wyld, M. Wozniak, N. Chaki, N. Meghanathan, D. Nagamalai (Eds.), *Advances in computing and information technology* (pp. 99–106). Berlin: Springer.
12. Koopman, P., Wagner, M. (2016): Challenges in autonomous vehicle testing and validation. In SAE world congress (pp. 1–10).
13. Schyr, C., Brissard, A. (2016): DrivingCube—a novel concept for validation of powertrain and steering systems with automated driving functions. In 13th international symposium on advanced vehicle control. Boca Raton: CRC Press.
14. Gruber, A., Gadringer, M. E., Schreiber, H., Amschl, D., Bösch, W., Metzner, S., Pflügl, H. (2017): Highly scalable radar target simulator for autonomous driving test beds. In European radar conference (pp. 147–150). New York: IEEE.
15. Gadringer, M. E., Schreiber, H., Gruber, A., Vorderderfler, M., Amschl, D., Bösch, W., Metzner, S., Pflügl, H., Paulweber, M. Virtual reality of automotive radars, E&I, *Elektrotech. Inf.tech.* <https://doi.org/10.1007/s00502-018-0620-9>.
16. Gadringer, M. E., Maier, F. M., Schreiber, H., Makkapati, V. P., Gruber, A., Vorderderfler, M., Amschl, D., Metzner, S., Pflügl, H., Bösch, W., Horn, M., Paulweber, M. Radar target stimulation for automotive applications. *IET Radar Sonar Navig.* Accepted.
17. Jain, V., Heydari, P. (2012): Radar fundamentals. In *Automotive radar sensors in silicon technologies* (pp. 5–11). New York: Springer.

18. Kissinger, D. (2012): Millimeter-wave receiver concepts for 77 GHz. Automotive radar in silicon-germanium technology. Berlin: Springer.
19. Engelhardt, M., Pfeiffer, F., Biebl, E. (2016): A high bandwidth radar target stimulator for automotive radar sensors. In 2016 European radar conference (EuRAD) (pp. 245–248).
20. Lutz, S., Erhart, C., Walte, T., Weigel, R. (2014): Target simulator concept for chirp modulated 77 GHz automotive radar sensors. In 11th European radar conference. New York: IEEE.
21. Komiyama, H., Yoshida, T., Onda, T., Suzuki, H. (2017): Radar test system 24, 77 and 79 GHz radar target simulators. In European radar conference, workshop on automotive radar measurement solutions.
22. Graf, S., Roßmann, M. (2017): Ota radar test for autonomous driving based on a 77 GHz radar signal simulator. In European radar conference, workshop on automotive radar measurement solutions.
23. Skolnik, M. I. (2008): Radar handbook. 3rd ed. New York: McGraw-Hill.
24. Kpogla, D., Ng, C., Robertson, I. (2003): Shifted-quadrant microwave vector modulator. Electron. Lett., 39, 1058–1059.
25. Grajal, J., Gismero, J., Mahfoudi, M., Petz, F. (1997): A 1.4–2.7-GHz analog MMIC vector modulator for a crossbar beamforming network. IEEE Trans. Microw. Theory Tech., 45(10), 1705–1714.
26. Devices, A. (2004): Vector modulator ICs make it easy to control phase and gain. In High frequency electronics (pp. 60–61).
27. Lee, T., Hajimiri, A. (2000): Oscillator phase noise: a tutorial. IEEE J. Solid-State Circuits, 35, 326–336.
28. Weinberg, A. (1980): The effects of transponder imperfections on the error probability performance of a satellite communication system. Trans. Commun., 28, 858–872.
29. Fei, L. F. (2005): Frequency divider design strategies, RF Design 18–26.
30. Kim, D. D., Cho, C., Kim, J., Plouchart, J.-O., Lim, D. (2008): A low-power mmWave CML prescaler in 65 nm SOI CMOS technology. In Compound semiconductor integrated circuits symposium. New York: IEEE.
31. Ali, U., Bober, M., Thiede, A., Wagner, S. (2015): 100–166 GHz wide band high speed digital dynamic frequency divider design in 0.13 μm SiGe BiCMOS technology. In 10th European microwave integrated circuits conference (EuMIC) (pp. 72–76). New York: IEEE.
32. Rategh, H., Lee, T. (1999): Superharmonic injection-locked frequency dividers. IEEE J. Solid-State Circuits, 34, 813–821.
33. Miller, R. L. (1939): Fractional-frequency generators utilizing regenerative modulators. In Proceedings of the IRE (Vol. 27, pp. 446–457). New York: IEEE.
34. Derksen, R., Luck, V., Rein, H.-M. (1991): Stability ranges of regenerative frequency dividers employing double balanced mixers in large-signal operation. IEEE Trans. Microw. Theory Tech., 39(10), 1759–1762.
35. Harrison, R. G. (1989): Theory of regenerative frequency dividers using double-balanced mixers. In MTT-S international microwave symposium digest, New York: IEEE.
36. Helstrom, C. (1965): Transient analysis of regenerative frequency dividers. IEEE Trans. Circuit Theory, 12, 489–497.

Authors



Michael Vorderderfler

studied information and computer engineering (telematics) at Graz University of Technology, Austria, and received his master's degree (Dipl.-Ing.) in 2016. During his studies, he focused on telecommunication and system-on-chip design. In the course of his master's thesis he deepened his skills in microwave engineering and small antennas and gathered 2 years of practical experience in this field

at semiconductor industry within his internship at Infineon Austria. Since 2016 he has been working as a scientific assistant at the Institute of Microwave and Photonic Engineering at Graz University of Technology. He started his Ph.D. study in summer 2016 with the focus on microwave circuit design, especially alternative frequency translation techniques at millimetre wave frequencies.



Michael E. Gadringer

received the Dipl.-Ing. and the Dr. techn. degrees from Vienna University of Technology, Austria, in 2002 and 2012, respectively. In July 2010 he changed to the Institute of Microwave and Photonic Engineering at Graz University of Technology, Austria. Since 2016, Michael Gadringer has been holding a tenure track research and teaching position at this institute. During his studies he was involved

in the design of analogue and digital linearisation systems for power amplifiers and in the behavioral modeling of microwave circuits. In his current research activities he focuses on the design and linearisation of broadband microwave and mm-wave communication systems. Additionally, he is involved in planning and implementing complex measurements with an emphasis on calibration and de-embedding techniques. Michael Gadringer has authored 13 journal and 32 conference papers. He fielded three patents and has co-edited the book "RF Power Amplifier Behavioral Modeling", published by Cambridge University Press.



Helmut Schreiber

graduated to Dipl.-Ing. in electrical engineering in 1993 and Dr. techn. in 2007, both at Graz University of Technology, Austria. His professional career started in 1993 at the Institute of Communications and Wave Propagation. Since 2011 he has been project-senior-scientist at the Institute of Microwave and Photonics Engineering of Graz University of Technology. His main research focus lies in

the area of radar technology where he developed amongst others radar systems for the measurement of snow avalanches. Another major research topic is microwave propagation in which context he wrote multiple studies regarding the interference effects of structures like wind turbines or tower buildings on airtraffic-surveillance and navigation systems.



Andreas Gruber

studied information and computer engineering at Graz University of Technology, Austria, with focus on telecommunication. Since January 2011 he has been employed at the Institute of Microwave and Photonic Engineering at Graz University of Technology, working as a system and hardware development engineer in the field of radar technology. He is member of IEEE and the Association of Old Crows.



Wolfgang Bösch

joined the Graz University of Technology, Austria, in March 2010 to establish a new Institute for Microwave and Photonic Engineering. Prior he was the CTO of the Advanced Digital Institute in the UK, a not for profit organisation to promote research activities. Earlier he served as the Director of Business and Technology Integration for RFMD UK, and for almost ten years he was with Filtronic plc as CTO of Filtronic Integrated Products and the Director of the Global

Technology Group. Before joining Filtronic, he held positions at the European Space Agency (ESA) working on amplifier linearization techniques, MPR-Teltech in Canada working on MMIC technology projects and the Corporate R&D group of M/A-COM in Boston, USA, where he worked on advanced topologies for high efficiency power amplifiers. For four years he was with DaimlerChrysler Aerospace (now Airbus) in Germany working on T/R modules for airborne radar. Professor Bösch received his engineering degrees from the Technical University of Vienna and Graz in Austria. He finalised his MBA with distinction at Bradford University School of Management, UK, in 2004. He is a Fellow of the IEEE and a Fellow of the IET. He has published more than 100 papers and holds 4 patents. He was a Non-Executive Director of Diamond Microwave Devices (DMD) and the Advanced Digital Institute (ADI). He is currently a Non-Executive Director of VIPER-RF company in the UK.



Steffen Metzner

is technology scout for the Instrumentation and Test Systems (ITS) division at AVL. He studied electrical engineering specialised in automation technologies at the University of Applied Science in Aachen, Germany, and control engineering at Coventry University, UK. Steffen joined AVL in 2007 as lead engineer responsible for the embedded systems software development process. In his current

position he is responsible for the research projects regarding autonomous driving in his division.



Horst Pflügl

received the Dipl.-Ing. degree from the Technical University of Graz in the field of electrical engineering/automation in 1995. He started his professional career at AVL as software developer for optimization software for engine control units and worked later as Head of Development. In this position he was responsible for the development and innovation strategy, he generated several patents as

well as scientific publications and supported Master and Ph.D. students in this field of expertise. Since 2010 he has been in a central research department of AVL responsible for the research program management of own and publicly funded research projects for the strategic business unit ITS (instrumentation and test systems), where he successfully set up and partly led important European research projects (CRYSTAL, ENABLE-S3, ASTERICS, OBELICS) in the area of vehicle development process, automated driving and electric driving.



Michael Paulweber

received a master degree and a doctorate in control theory from Graz University of Technology, Austria, in 2008; he then added an Executive MBA degree at the St. Marys College of California, USA. After working at Graz University of Technology, he joined AVL List GesmbH and became head of development for the test system automation and control product-line. He gained expert knowledge in

embedded software development. 2012 he was appointed director of global research and technology management in the AVL instrumentation and test system division. Michael Paulweber serves as vice president of the European Industry association ARTEMIS and is member of the European ECSEL steering board. He held lectures at a University of Applied Science as well as at Graz University of Technology.